

PERMAS Users' Conference, Stuttgart, 12/13 April 2018



***VisPER* Version 6**



Status of *VisPER*



Dr. Ove Sommer
INTES GmbH, Stuttgart
12.04.2018

Outline



- Overview on  **VisPER**
- New wizards in  **VisPER 6**
 - Assembly, Design (separate slots)
 - Pressfit and Sampling
- Extended, harmonized GUI
 - **\$DISLOAD***, **\$ELSYS**, **\$MPC GENERAL**
 - Similar appearance of wizards / dialog bars
- Enhanced Postprocessing
 - More options on result combination
 - Tensor visualization
- Summary

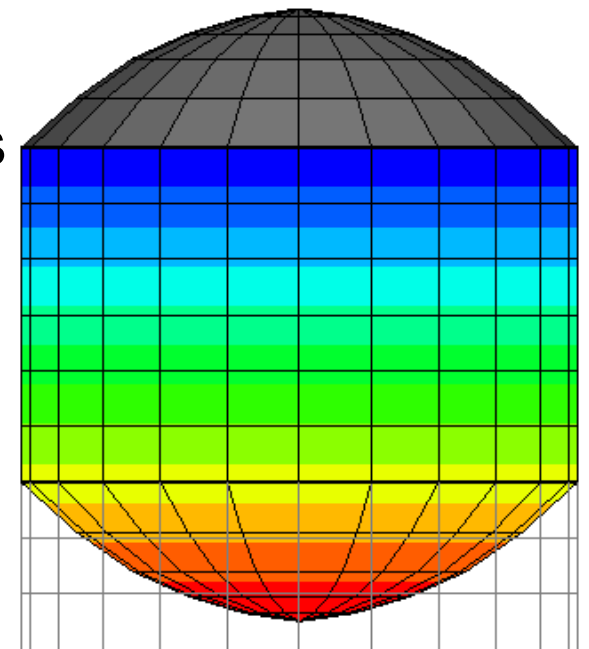
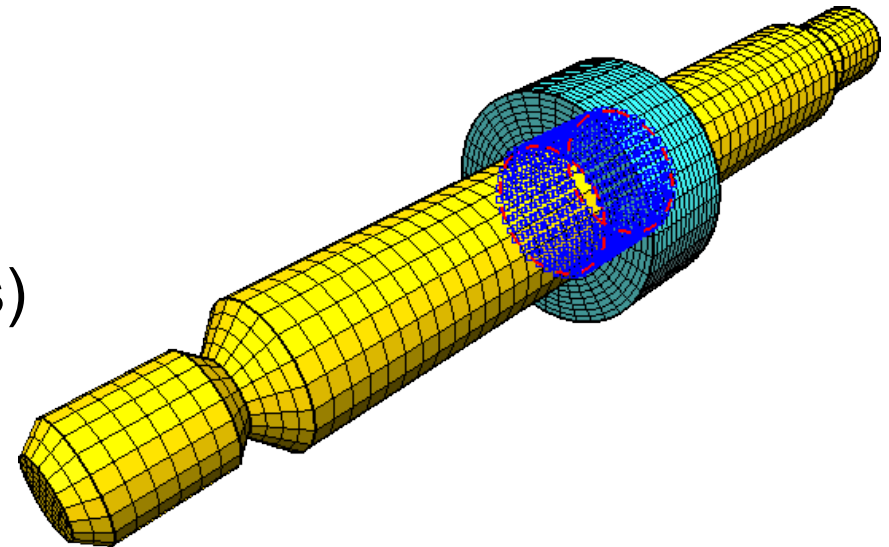

- 
VisPER directly integrates PERMAS

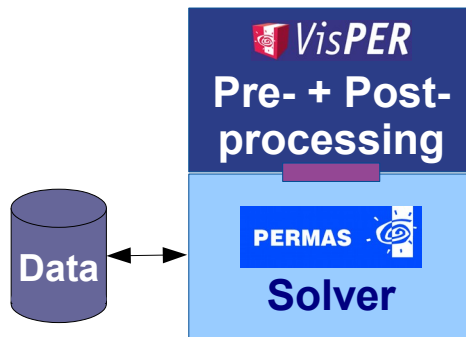

Common data model

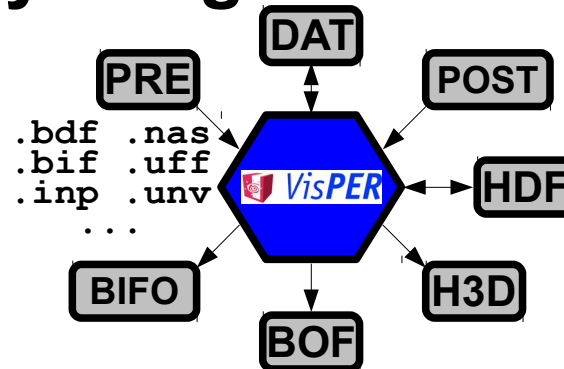

Various interfaces

- + Consistent data
- + Direct PERMAS access
- + PERMAS-specific model completion
- + Flexible process chain

- 
VisPER wizards support specific modeling steps

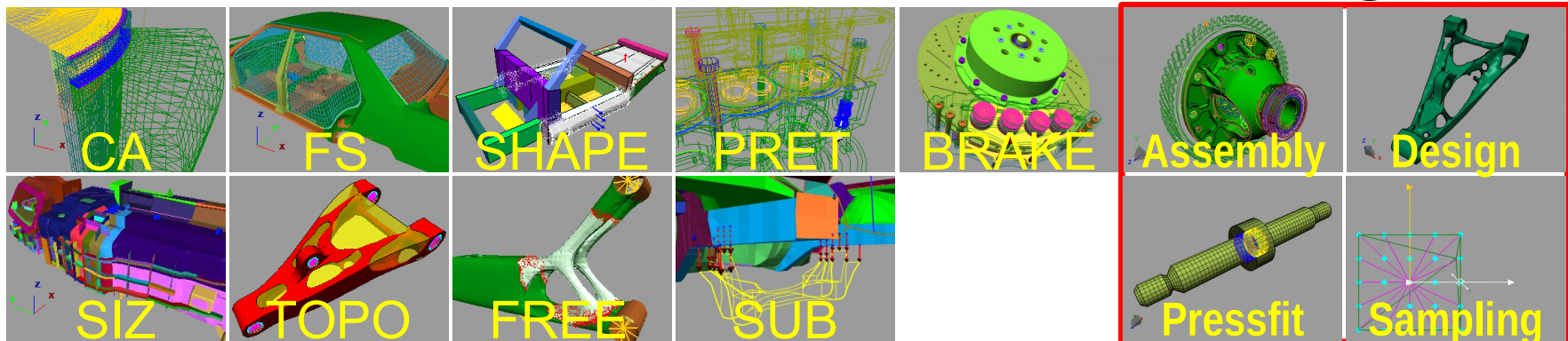

New

- 
VisPER provides dedicated postprocessing func.

- Partial structure replace made easy

Select elements to be replaced
Load replacement structure
Verify and adjust reconnection
Verify replaced structure

- Wizard key features
 - No preparation required
 - Label conflicts resolved automatically
 - Interactive positioning possible
 - Automatic reconnection to environment
 - Context driven verification process
- Ensures process stability and saves time

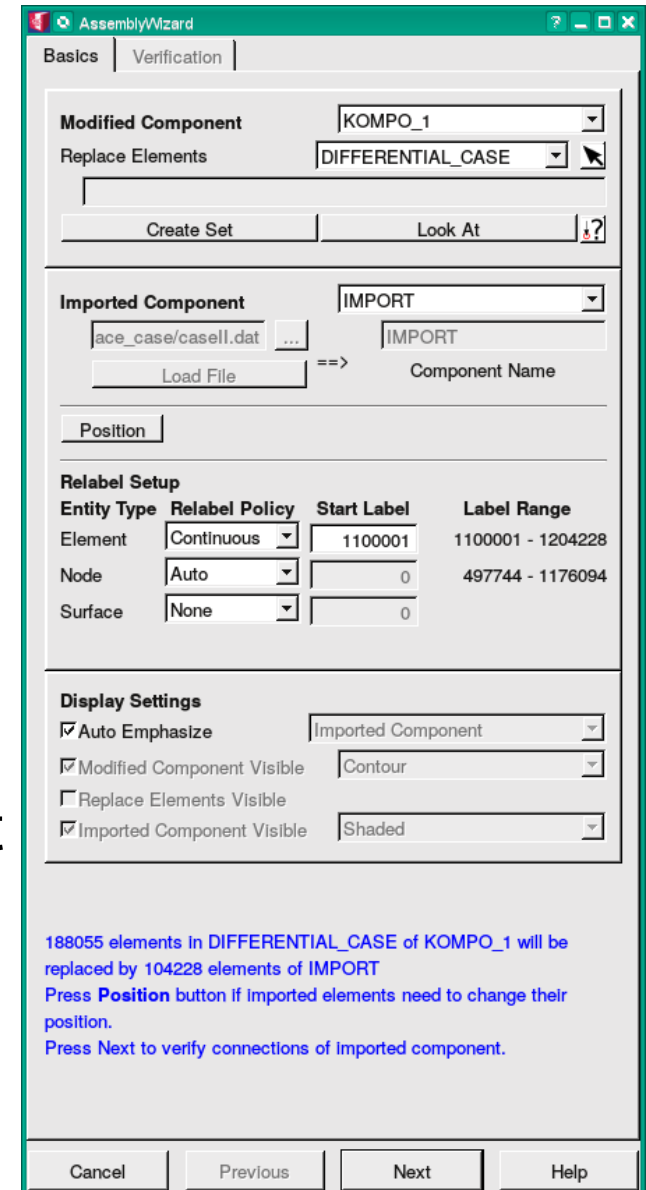

VisPER 6 – AssemblyWizard (2)



AssemblyWizard

Basics | Verification

Modified Component: KOMPO_1

Replace Elements: DIFFERENTIAL_CASE

Imported Component: IMPORT

Position

Reconnect Setup

| Entity | Type | Replaced | Position | Start Label | End Label |
|---------|------------|----------|----------|-------------------|-----------|
| Element | Continuous | 1100001 | | 1100001 - 1204228 | |
| Node | Auto | | | 497744 - 1176094 | |

Display Settings

- Auto Emphasize: Imported Component
- Modified Component Visible: Contour
- Replace Elements Visible
- Imported Component Visible: Shaded

188055 elements in DIFFERENTIAL_CASE of KOMPO_1 will be replaced by 104228 elements of IMPORT

Press Position button if imported elements need to change their position.

Press Next to verify connections of imported components.

Cancel Previous Next Help

AssemblyWizard

Basics | Verification

GSYS

Create Delete

+ Origin

0 0 0

+ Euler Angles

0 0 0

+ Direction 1

0 1 0

Align Points Align Lines

Undo Redo Reset

Assembly Result

Add&Replace Overview

| Entity / | Doctype | Modified | New | Deleted | Status |
|-----------|---------|----------|--------|---------|----------|
| COORD | None | 39786 | 146077 | 84 | replaced |
| ELEMENT | None | 0 | 104228 | 188055 | replaced |
| ESET | None | 1 | 0 | 0 | replaced |
| MPC RIGID | DISP | 2 | 0 | 0 | replaced |
| NSET | None | 2 | 0 | 0 | replaced |
| SURFACE | None | 69 | 0 | 0 | replaced |

Cancel Previous Next Help

AssemblyWizard

Basics | Verification

Affected Reconnection Entities (Structure)

| Entity / | Doctype | Reconnected | Unconnected | Mod. Co |
|------------|---------|-------------|-------------|---------|
| MPC RIGID | DISP | 0 | 2 | |
| NSET | None | 0 | 4 | |
| PRETENSION | None | 0 | 4 | |
| SURFACE | None | 0 | 76 | |

Unconnected Reconnected Fixed

Show Node Context

168 0 362

Reconnection Parameters

Node Distance Tolerances

+ Type Fil... All Same Type Distance: 1.81

Any Type Distance: 9.03

Surface Patch Tolerances

Normal Distance: 1.81

Inplane Distance: 7.22

Max. Difference Angle: 15

Reconnect entities of all types.

Reconnect Reset Connection

Cancel Previous Finish Help

AssemblyWizard will be presented in the next talk in more detail showing several scenarios in an online demo

→ M.Klein: Making PERMAS model assembly effective by VisPER

- Support of simulation driven design

Generate and smooth hull

Repair hull mesh

Add and check manufacturing constraints

Generate TET mesh from hull

- Wizard key features

- Close gap between TOPO and SHAPE
- Produce well-formed hull-mesh
- Provide several hull mesh repair tools
- Provide check options for manufacturing restrictions
- Make use of external TET-meshers

→ Accelerates early design phase

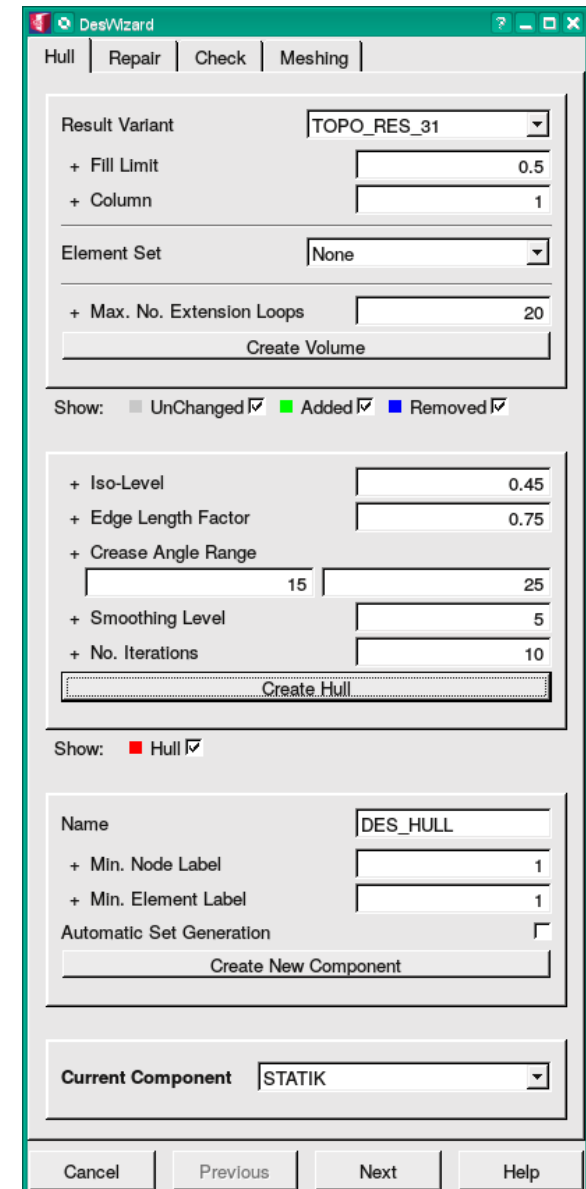

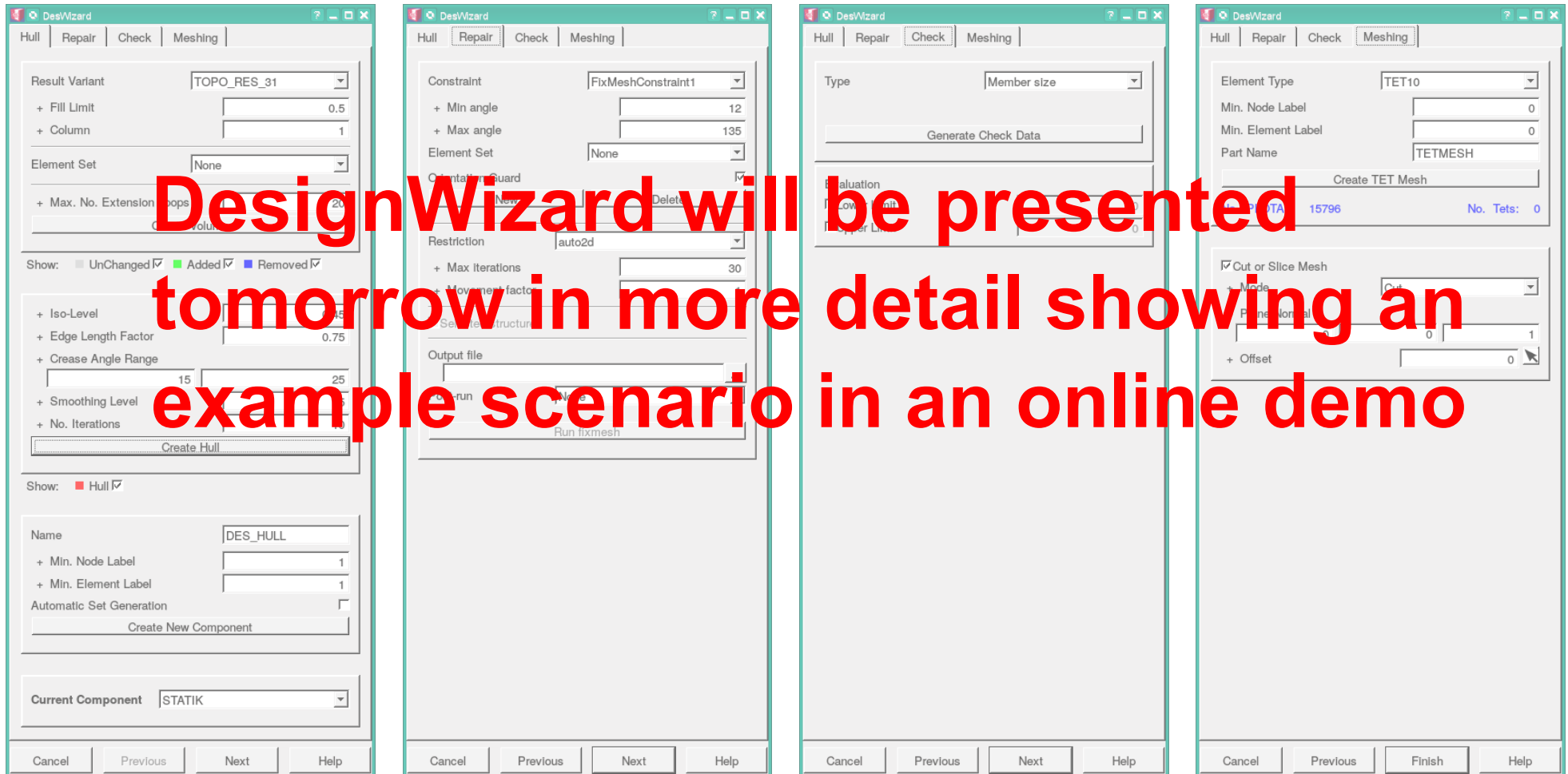

DesignWizard will be presented tomorrow in more detail showing an example scenario in an online demo

→ R.Fischer: Efficient design creation and validation

- PressfitWizard

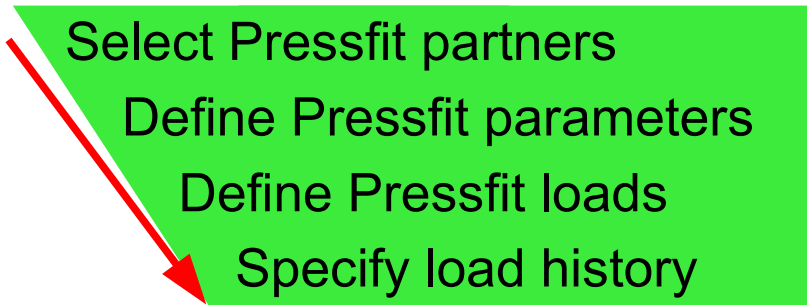

\$PRESSFIT definition supported by new wizard

- Same look-and-feel as ContactWizard ensures fast familiarization
- Visual feedback provides direct response to definition

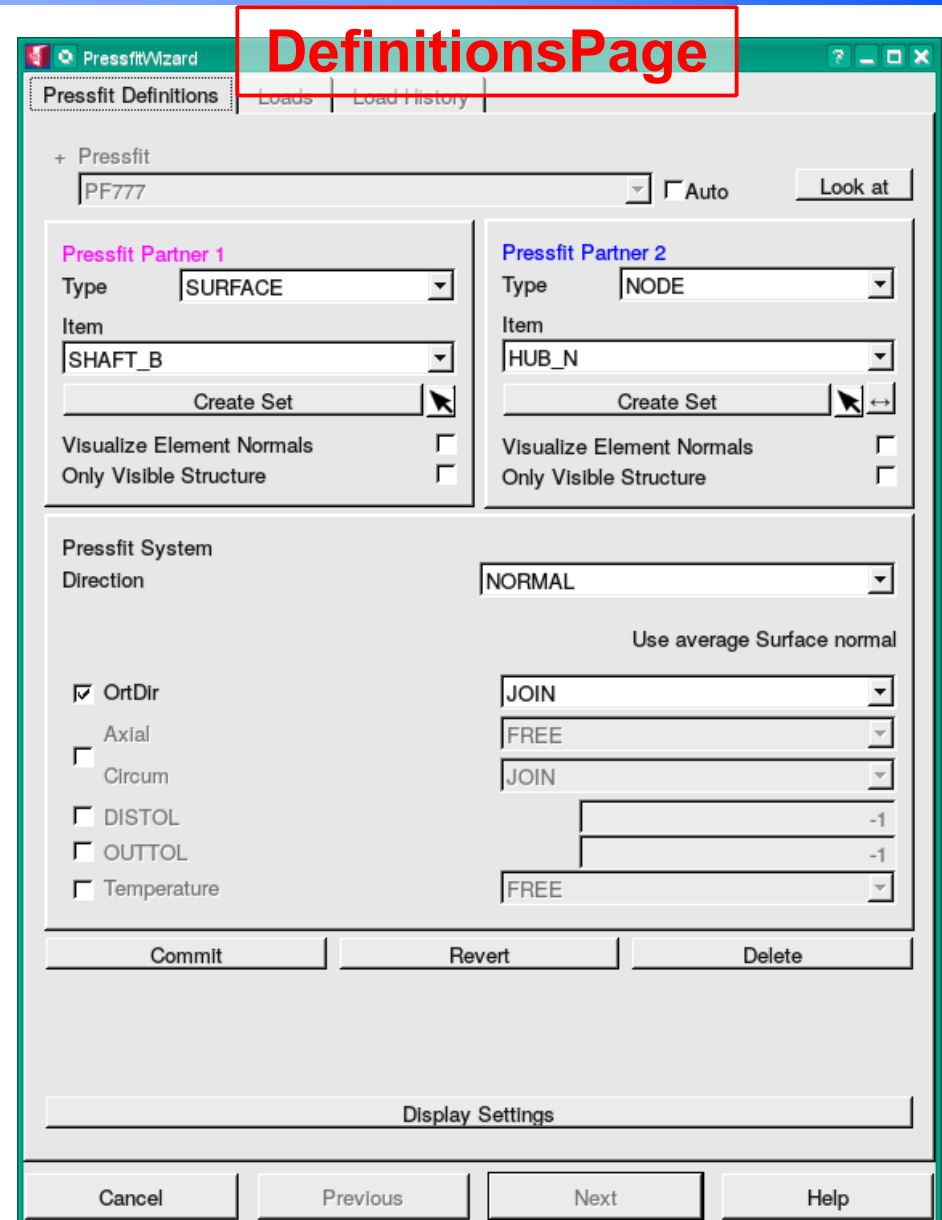

- Different colors easily allow to distinguish contact partners and to be aware of the node status of selected **\$PRESSFIT** definition

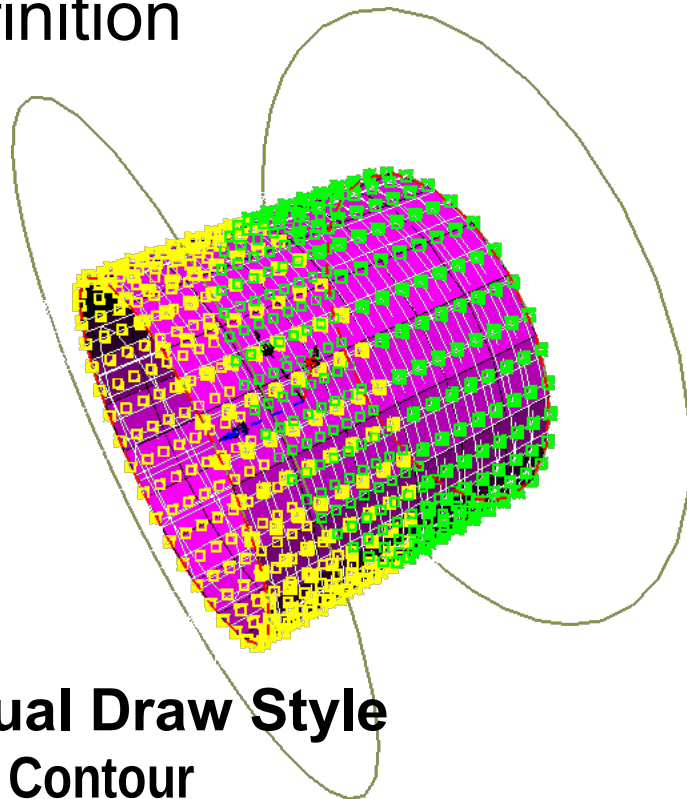

**Residual Draw Style
Mode: Contour**

LoadsPage

PressfitWizard

Pressfit Definitions | Loads | Load History

Situation: <None> Config...

Loading Variant: DFLTLOAD

- Pressfit Load Table

| Pressfit / | LPAT | NodeSet | Overlap | Value | Function | ArgList | RSYS |
|------------|------|------------|---------|-------|----------|---------|------|
| PF777 | 1001 | NHUB LEFT | ABS | 1 | 101 | z 18 | |
| PF777 | 1001 | NHUB RIGHT | ABS | 1 | 101 | z 17 | |

None | All | Look at

- Function arguments

| x(l) | arg |
|------|-----|
| 1 | z |

Add New Load

<Create LPAT> | 1001 | Add

Color Legend: ■ Current ■ Different ■ Conflict ■ Partner 1 ■ Partner 2

Cancel | Previous | Next | Help

- Complex sampling setup via wizard

Prepare sampling situation

Property variable assignment

Definition of sample values

Result item specification

- Wizard key features

- Seamless setup of DOEs
- Available sampling variables for DOEs: Shape, Sizing, Material, ...
- Less error-prone setup due to machine generated files

→ **Ensures process stability**

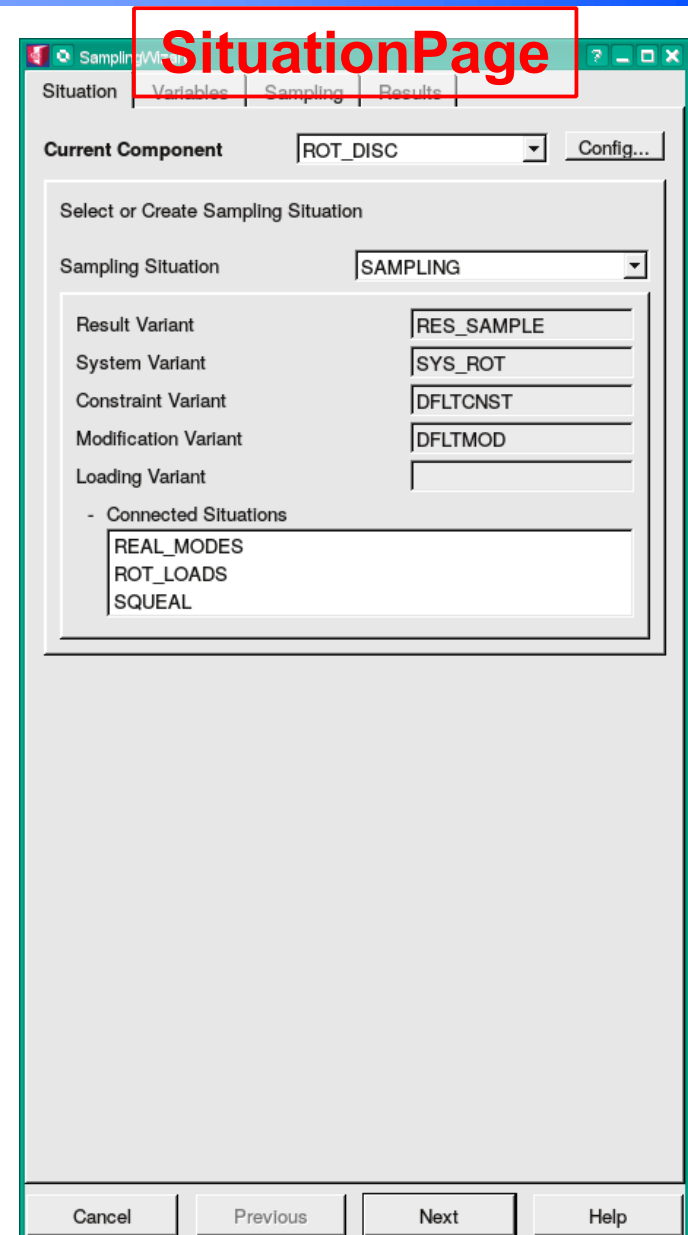

VisPER 6 – SamplingWizard (2)



VariablesPage

Situation Variables **Sampling** Results

- Existing Variables

| Variables / | From | Info |
|-------------|-----------------------|-----------------------|
| [101] | DESIGN_ELEMENT_800001 | Material, DHEXE8 |
| [201] | DESIGN_ELEMENT_800002 | Contlockfric, DSYSTEM |

Geometry Material

System (CONTLOCKFRIC) Linking

Cancel Previous Next Help

Setup of sampling variables for different scenarios on wizard sub-pages

GeometrySubPage

Situation Variables **Sampling** Results

+ Design Element DESIGN_ELEMENT_800001

Element Set PAD

Type DHEXE8

Design Variables 101

Commit Revert Delete

Geodat Type

Geodat Name

- Geodat Fields

| Field / | Index | Variable |
|---------|-------|----------|
|---------|-------|----------|

- Initial Values

| Var. / | Value |
|--------|-------|
| 101 | 500 |

SystemSubPage

Situation Variables **Sampling** Results

+ Design Element DESIGN_ELEMENT_800002

Type DSYSTEM

Design Variables 201

Commit Revert Delete

- CONTLOCKFRIC

| Contact / | Function | Design Var. |
|-----------|----------|-------------|
| 7001 | | 201 |
| 7002 | | 201 |

Delete

Contact None Create

MaterialSubPage

Situation Variables **Sampling** Results

+ Design Element DESIGN_ELEMENT_800001

Element Set PAD

Type DHEXE8

Design Variables 101

Commit Revert Delete

- Material Properties

| Mat / | Prop | Index | Fac. | Var. |
|--------|---------|-------|-------|------|
| PADMAT | ELASTIC | 1 | 0.002 | 101 |
| PADMAT | DENSITY | - | - | - |
| PADMAT | DAMPING | - | - | - |

- Initial Values

| Var. / | Value |
|--------|-------|
| 101 | 500 |

LinkingSubPage

Situation Variables **Sampling** Results

- Linking

| Type / | Dependent | Guiding | Factors/Func |
|--------|-----------|---------|--------------|
|--------|-----------|---------|--------------|

Delete

Type SAME

Dependent Variables

Guiding Variables

Create

Visualize Variable 0

Ranges: [101,201]

Sampling

VisPER 6 – SamplingWizard (3)



- Define sampling value range for each variable on SamplingPage
- On ResultsPage specify the result items that should be exported

SamplingPage

Situation | Variables | Sampling | Results

- Sampling

| VarId | VarType | ValuesType | Values |
|-------|-------------|----------------|------------------|
| 101 | Design Var. | Equal Interval | [300, 700] Δ=100 |
| 201 | Design Var. | Equal Interval | [0.2, 0.8] Δ=0.2 |

Delete

VarType: Design Var.
VarId: 0
ValuesType: Logarithmic
Min: 0
Max: 0
Num. Log. Intervals: 1
Ranges: [101,201]
Create

Cancel Previous Next Help

ResultsPage

Situation | Variables | Sampling | Results

+ Result Item: FRQ_M11_4X5

Type: CAMPBELL
Situation: SQUEAL
Region: GLOBAL
Mode ID: 11
Domain: FREQUENCY All
REAL
4.5
+ DOF/IComp. 5

Commit Revert Delete

+ Extraction Rule: SAMPLING_CFREQ_M11_4

Function: None No. Items: 1
 All Values

| Component | ResultItem | NumValues | SearchKey |
|-----------|------------|-----------|-----------|
| <Default> | FRQ M11 4 | 1 | EXTREME |

Show Component Column

Commit Revert Delete

Cancel Previous Finish Help

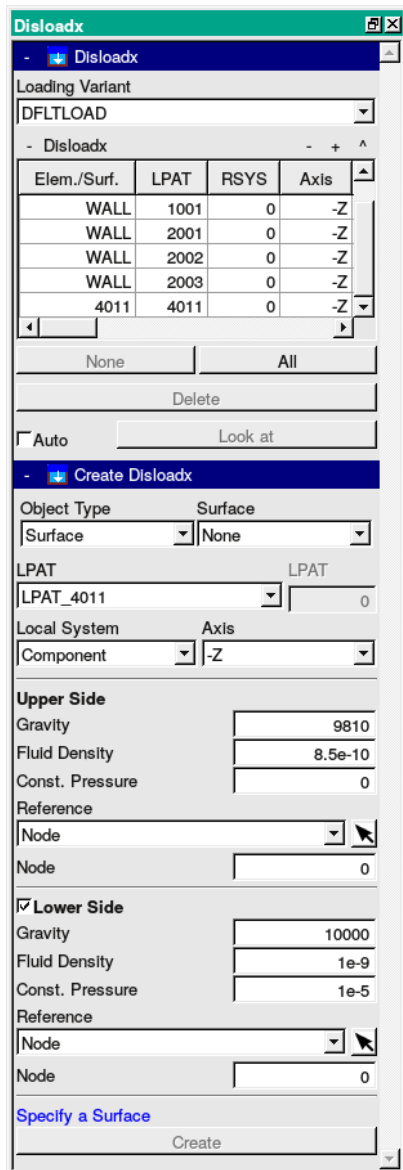

- Handle distributed loads defined
 - at structural nodes: **\$DISLOADN**
 - at surfaces: **\$DISLOADS**
 - due to hydrostatic pressure: **\$DISLOADX**
- Disload*DB (Variants→Loading→...)
- Overview of existing **\$DISLOAD*** definitions
- Definition of new distributed loads
- Visualization of corresponding regions
- Color- or vector-based visualization of distributed loads via VisualizationDB  (e.g. verification and validation of position-dependent pressure loads)

Setup of Distributed Loads extended

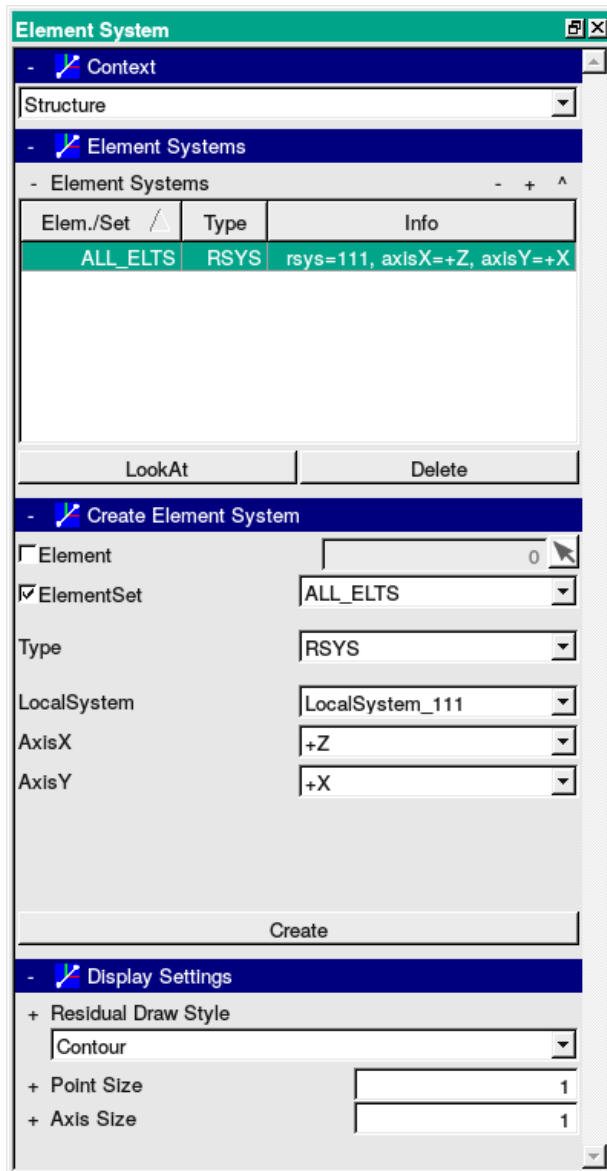

- Local element systems: **\$ELSYS**
- ElementSystemDB
(Structure→ElementSystem)
- Overview of existing **\$ELSYS** definitions
- Visualization of corresponding elements and their systems
- Definition of new element systems
- Supported in both contexts, **\$STRUCTURE** and **\$SYSTEM**

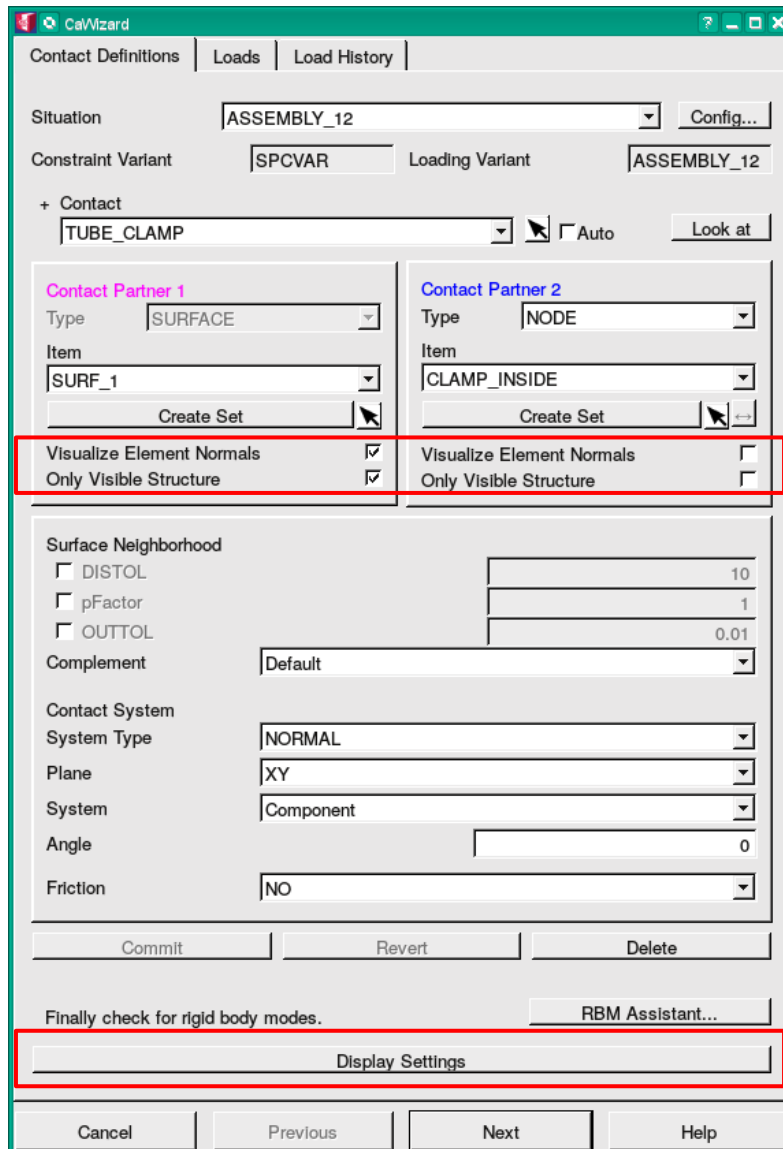

- Contact-related wizards harmonized (Contact, Pressfit, Pretension)
- Common extensions:
 - Optional visualization of element normals
 - Optional limitation of visible contact area to visible structure
 - Existing definitions can be modified (e.g. contact friction)
- Display Settings sub-page

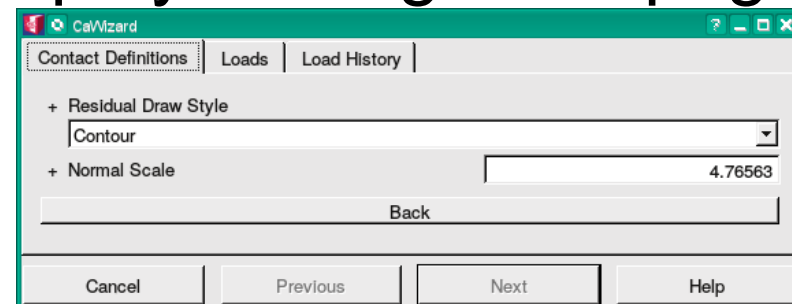

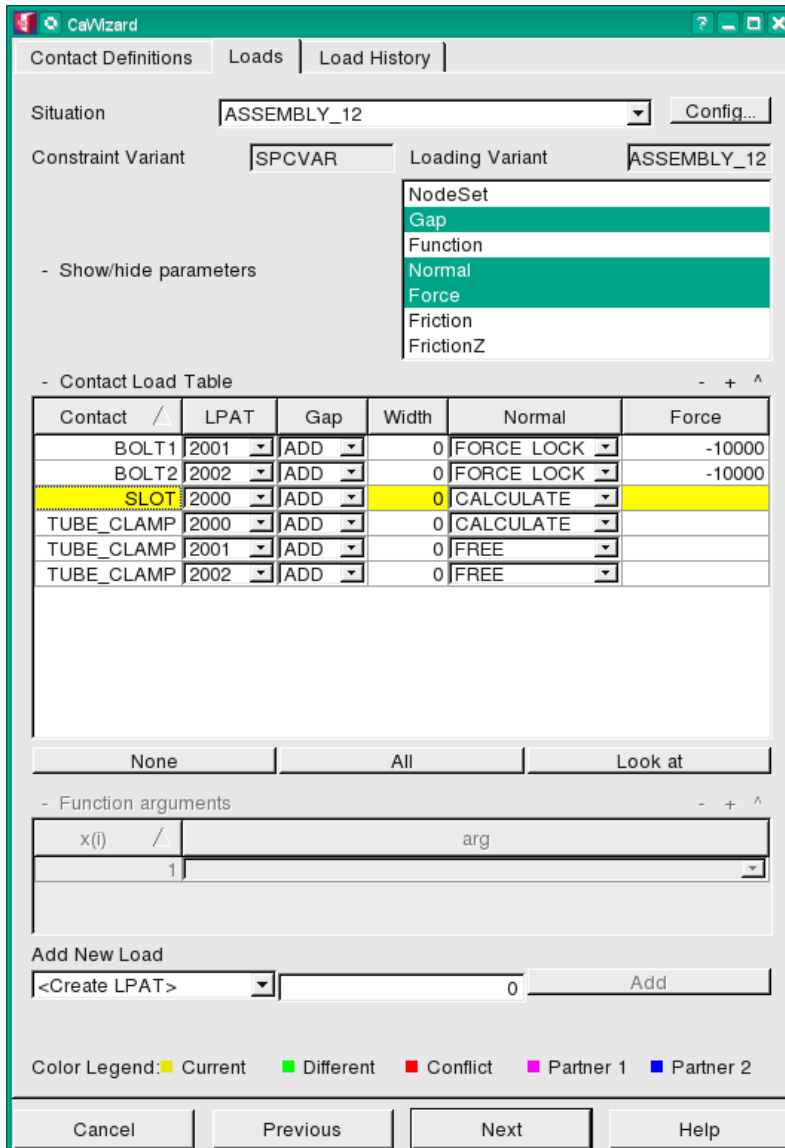

- LoadsPage extended
 - Overview over all definitions
 - Flexible load table with configurable column visibility
 - Support of **function-based contact loads**
 - More detailed visual feedback

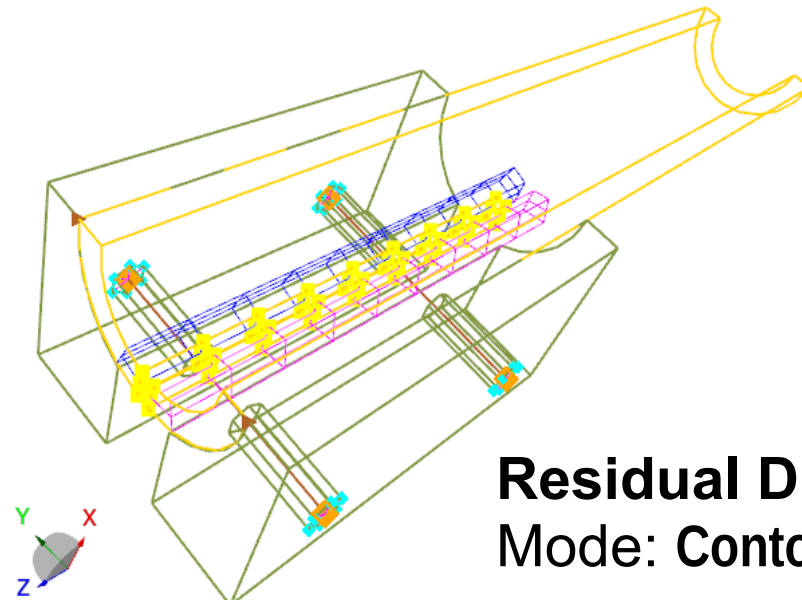

**Residual Draw Style
Mode: Contour**

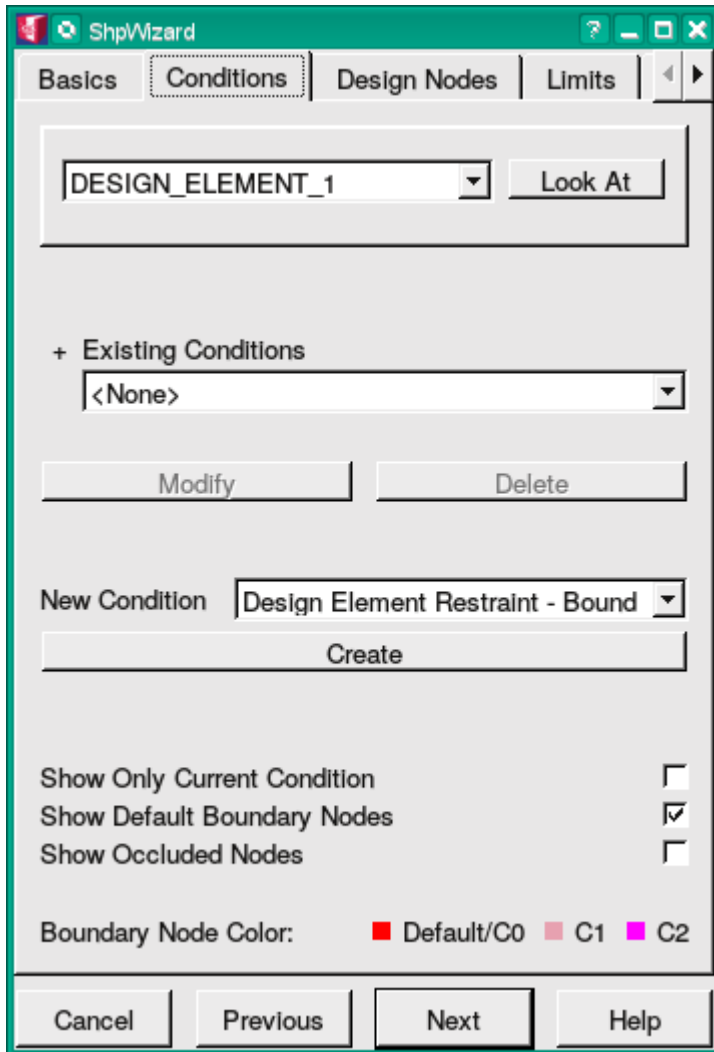

- ConditionsPage of FreeWizard and ShapeWizard unitized
- Support of release direction
- Enhanced visualization by displaying non-design regions in **Contour** mode
- Different coloring of boundary nodes
- More control over boundary node visibility

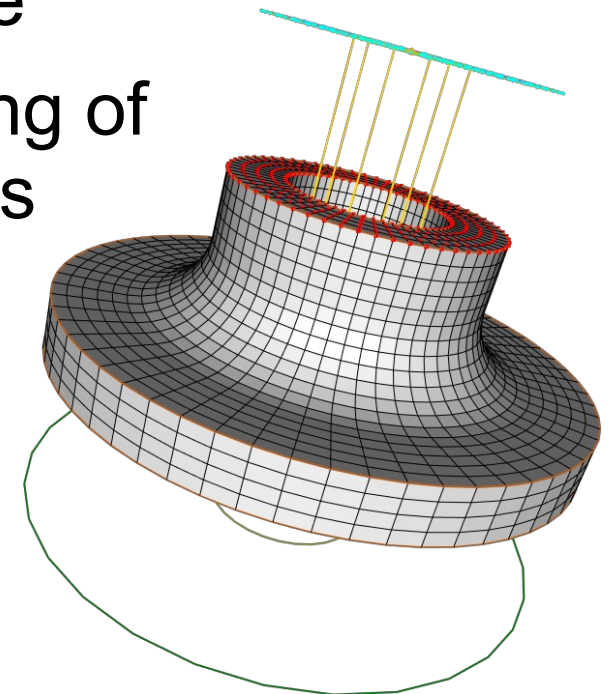

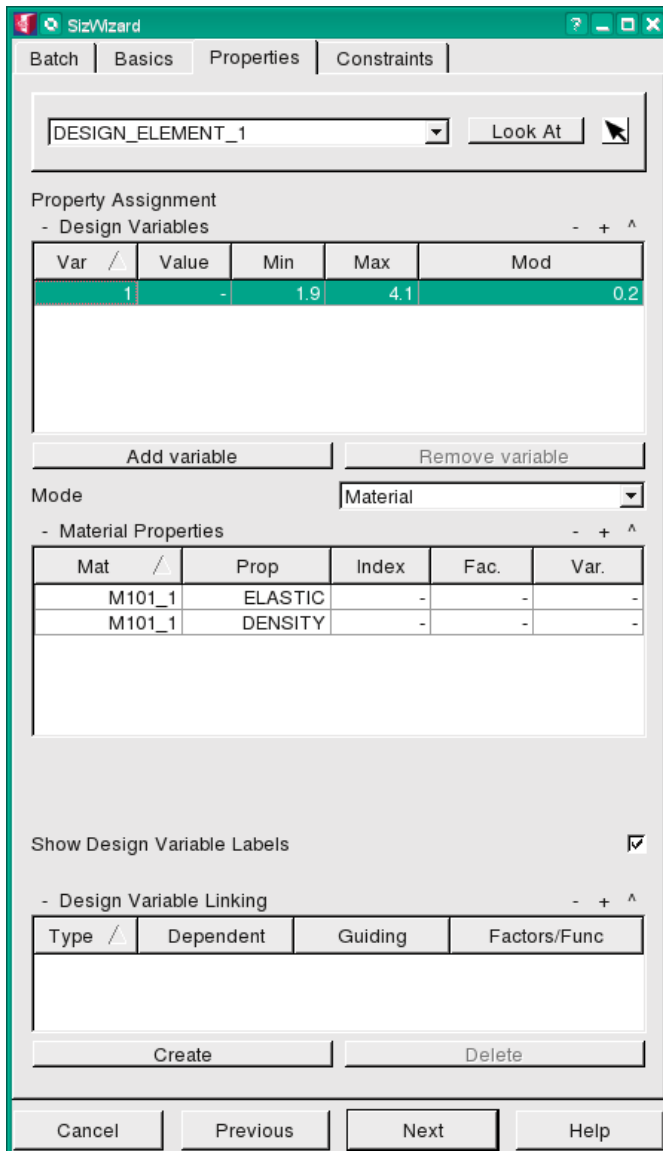

- SizingWizard extended
- Design variable linking **\$DSVLINK** supported for **\$DVGP** and **\$DVMP**
- Enhanced visualization

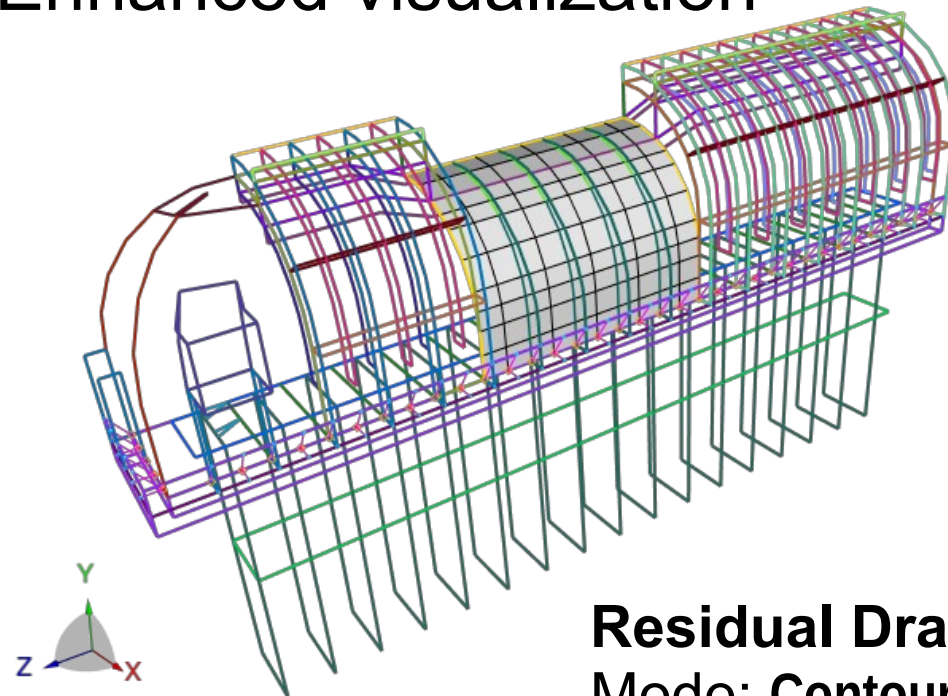

Residual Draw Style
Mode: Contour

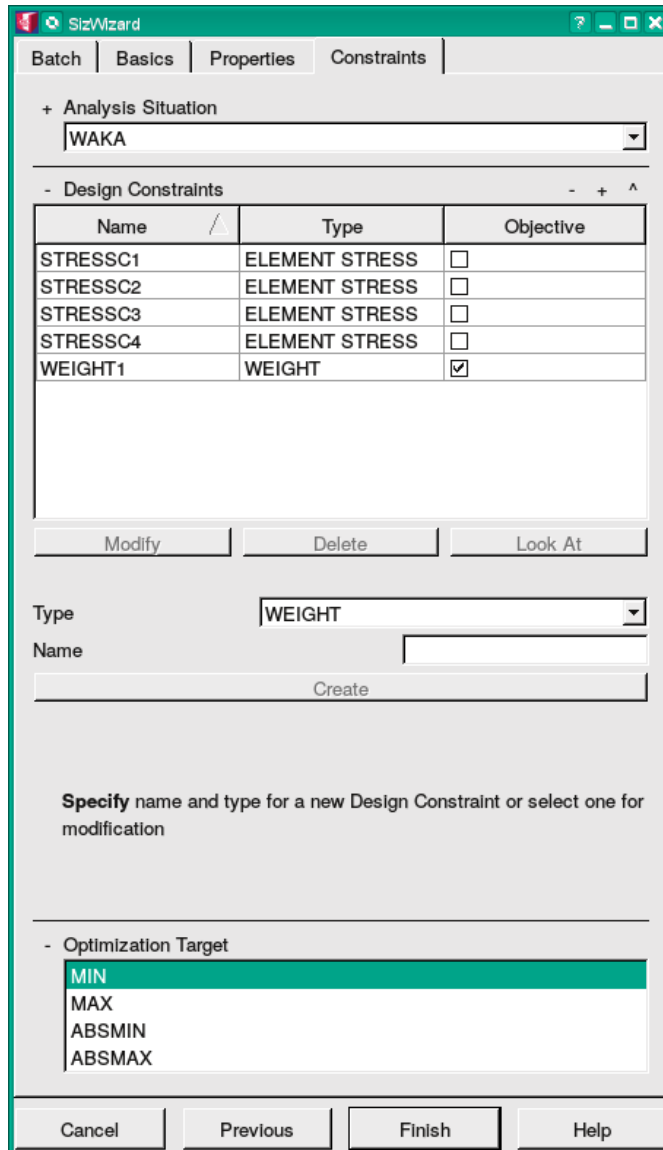

- ConstraintsPage of all optimization wizards provides an overview in the design constraints table
- Multiple objectives may be chosen by ticking the checkboxes in the right column



- New constraints for design optimization supported

ACCELERATION

CAMPBELL

COMPLEX FREQUENCY

COMPLIANCE

CONTACT GAP

CONTACT PRESSURE

CONTACT REAKTION FORCE

COORCHANGE

DISPLACEMENT

EFFECTIVE PLASTIC STRAIN

ELEMENT STRESS

ELEMENT TEST

FILL

FREQUENCY

HEATFLUX

NODAL POINT STRESS

NODAL POINT USER

NP EFFECTIVE PLASTIC STRAIN

NP STRESS COMPONENTS

PRINCIPAL STRESS

PRINCIPAL STRESS GRADIENT

REACTION FORCE

REACTION FORCE DEPENDENT

RELIABILITY

SOUND RADIATION POWER

SOUND RADIATION POWER DENSITY

SOUND RADIATION POWER SUM

STRESS RESULTANT

TEMPERATURE

VELOCITY

WEIGHT



VisPER 6 – Extended model info tree



| Item | Info |
|-------------------------|--|
| KOMPO_1 | 356226N 343848E |
| Nodes | Num=356226, MinId=1, MaxId=1437924 |
| Coords | Min=(-20.0352, -121.25, -121.244), Max=(125.4, 121.247, 121.249) |
| Elements | Num=343848, MinId=363269, MaxId=1079923 |
| MPC ISURFACE (DISP) | Num=11, MinId=200, MaxId=307 |
| MPC RIGID (DISP) | Num=2, MinId=525228, MaxId=525229 |
| MPC WLSCON (DISP) | Num=1, Id=525227 |
| RSYSs | Num=4, MinId=1, MaxId=4 |
| ROTBs | Num=14206 |
| PRETENSION THREAD | Num=8 |
| Situations | Num=1 |
| STATIC | CONSTRAINTS=C_01 SYSTEM=NSV LOADING=L_01 |
| C_01 | VarConstraint |
| SPC (DISP) | Num=2504 |
| CONTACT SURFACE | Num=23 |
| L_01 | VarLoading |
| DFLTMOD | VarModification |
| DFLTRES | VarResult |
| NSV | VarSystem |
| ELPROP | Num=20 |
| GEODAT SCALAR | Num=642 |
| GEODAT SOLID | Num=20 |
| DesignElements | Num=1 |
| NON_DESIGNELEMENT_ELEMS | 343848 Elems |
| Parts | Num=20 |
| ElemTypes | Num=4 |
| HEXE8 | 2544 Elems |
| PENTA6 | 528 Elems |
| TET4 | 188055 Elems |
| TET10 | 152721 Elems |
| Surfaces | Num=123 |
| SurfaceSets | Num=59 |
| NodeSets | Num=26 |
| ElementSets | Num=33 |
| NodeSetBins | Num=1 |

| Item | Info |
|----------------|------------------|
| Materials | 6 |
| BOLTMAT | 1 (HOMO ISO) |
| MAT_1 | 1 (HOMO ISO) |
| MAT_DIFF | 3 (HOMO ISO) |
| DENSITY | GENE DATA |
| ELASTIC | GENE DATA |
| THERMEXP | GENE DATA |
| MAT_OTHERS | 3 (HOMO ISO) |
| SHAFT1MAT | 1 (HOMO ISO) |
| SHAFT2MAT | 1 (HOMO ISO) |
| MatKinds | 1 |
| MATERIAL - ISO | 6 |
| BOLTMAT | 1 |
| MAT_1 | 1 |
| MAT_DIFF | 3 |
| DENSITY | GENE DATA |
| ELASTIC | GENE DATA |
| THERMEXP | GENE DATA |
| MAT_OTHERS | 3 |
| SHAFT1MAT | 1 |
| SHAFT2MAT | 1 |
| MatProps | 3 |
| DENSITY | 2 |
| MAT_DIFF | 3 |
| DENSITY | GENE DATA |
| ELASTIC | GENE DATA |
| THERMEXP | GENE DATA |
| MAT_OTHERS | 3 |
| ELASTIC | 6 |
| THERMEXP | 2 |
| MAT_DIFF | |
| Density | 7.85e-9 |

- Easy verification / model inspection using the Context functionality to go to specialized dialogs (Use popup-menu)
- Set of supported entity types has been extended
- Model information may be exported as Excel or Word document

Further extensions

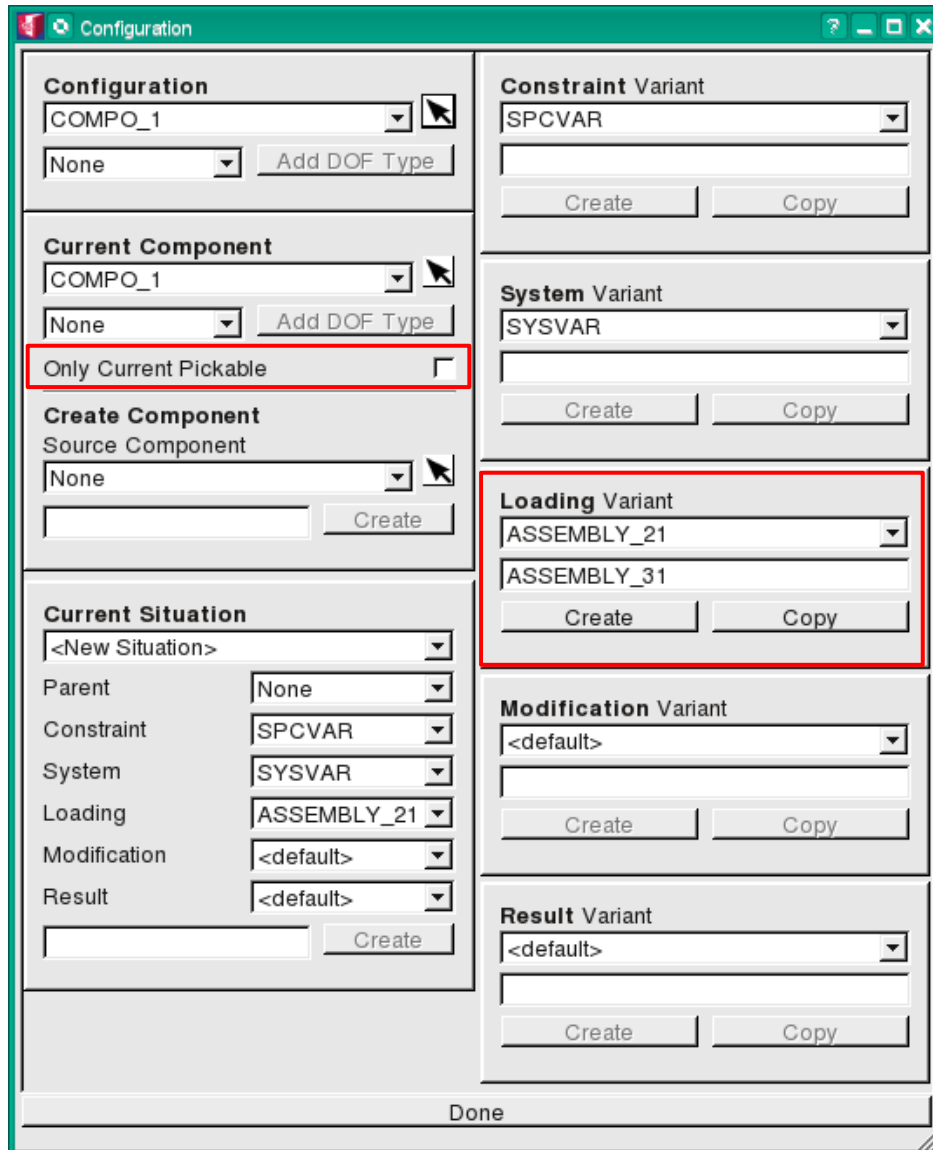

- Control if only the currently selected component can be picked
- **Variants can be copied**
Fast way to create several simulation variants by copy variants and modify some settings

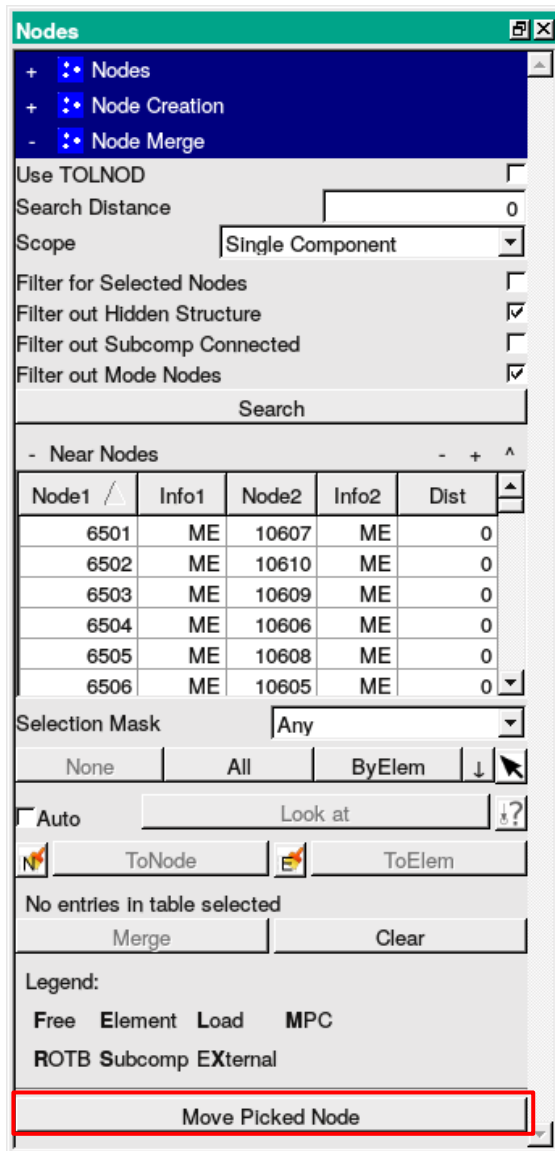

- **NodesDB**
Extended node merge functionality
- **ElementsDB**
Enhanced element creation by picking multiple nodes and creation of point elements via node selection
- **RelabelingDB**
New relabel policy
FixedOffFrom
- **SurfacesDB**
Visualize surface system and patch normal

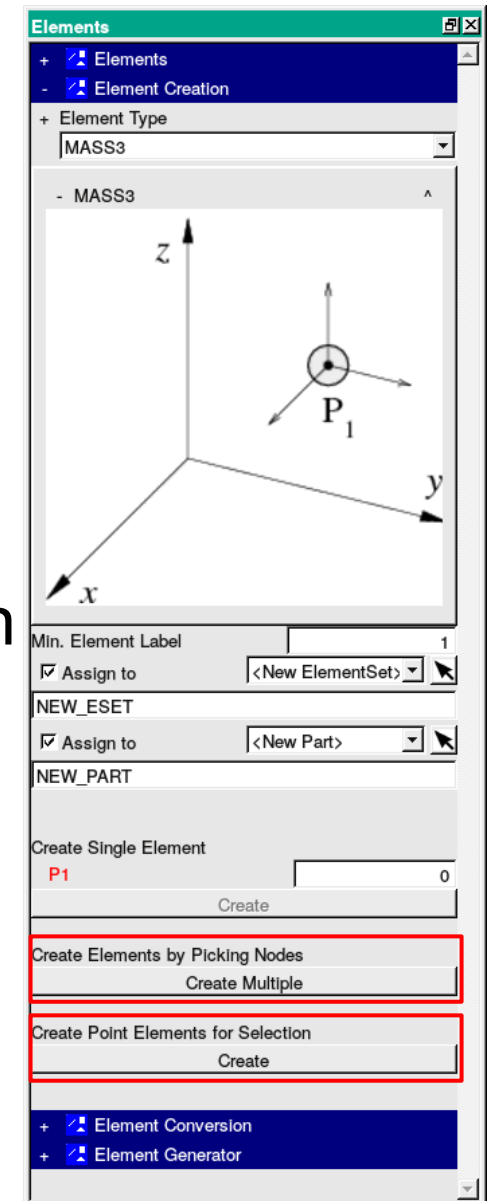

Further extensions

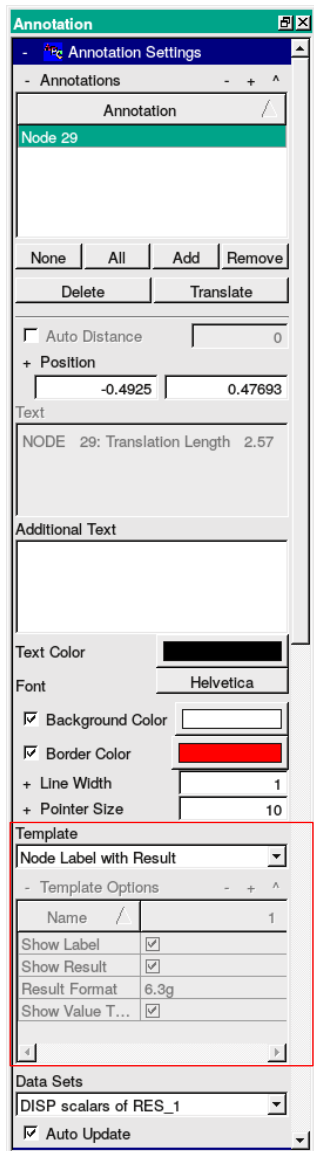

- **AnnotationDB**
Annotation template configurability extended
Contents and format can be specified
- **MPCsDB**
MPC definitions can be modified and
\$MPC GENERAL is supported
- **LocalSystemsDB**
 - **\$RSYS** definition by Euler rotations
 - New **\$RSYS** types **HELIX** and **THREAD**

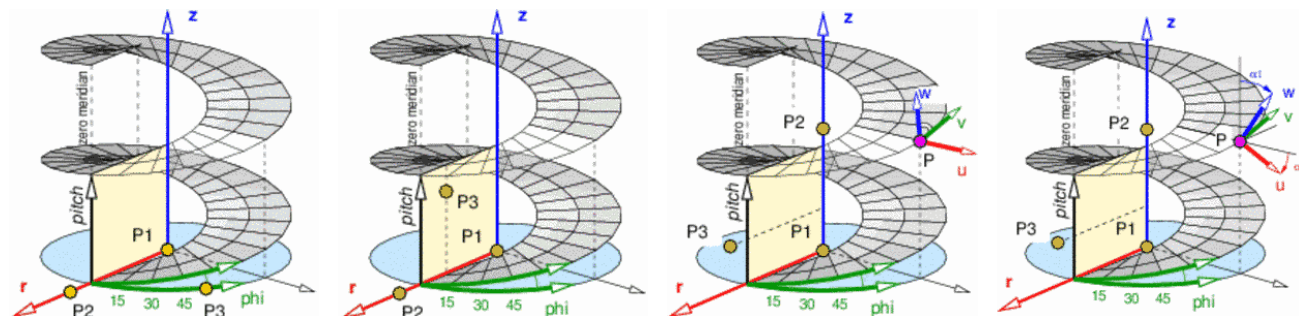



VisPER 6 – New Postproc. Capabilities (1)

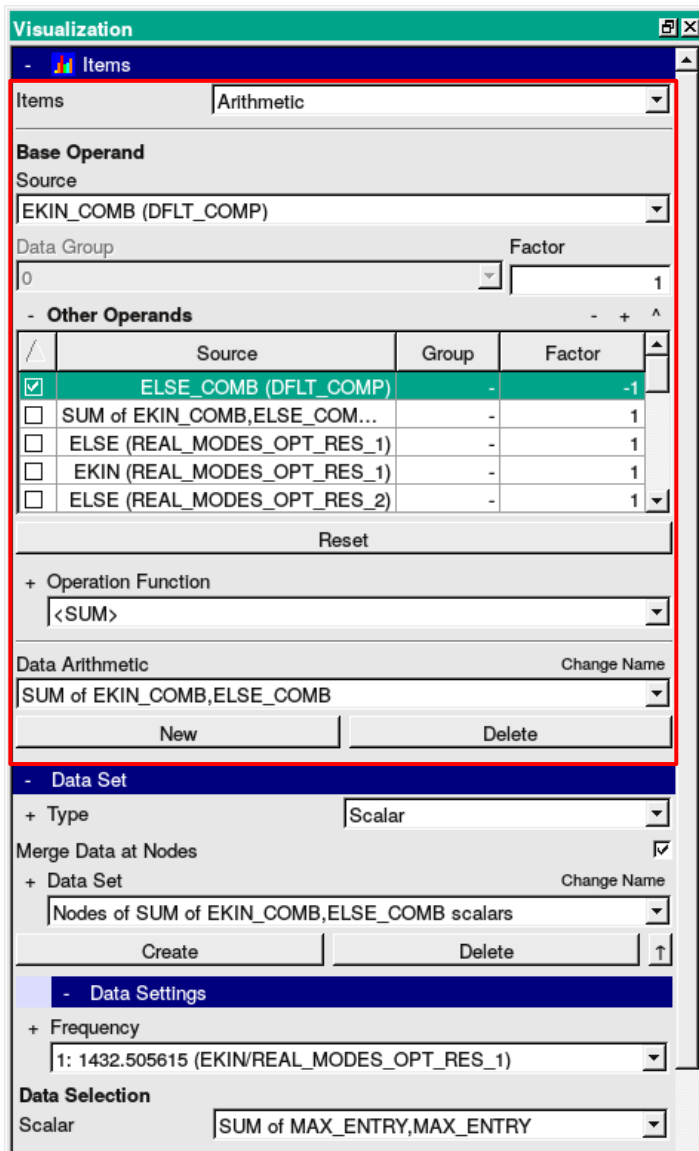

- **Arithmetic operation** on result combination possible (e.g. difference of **KINETIC** and **STRAIN ENERGY DENSITY**)
- Each single column may be used as operand
- Sum of scaled values is always possible
- Each PERMAS function with matching number of input parameters can also be chosen (e.g. logarithmic function to post-process acoustic levels [dB])

Extended postprocessing capabilities



VisPER 6 – New Postproc. Capabilities (2)

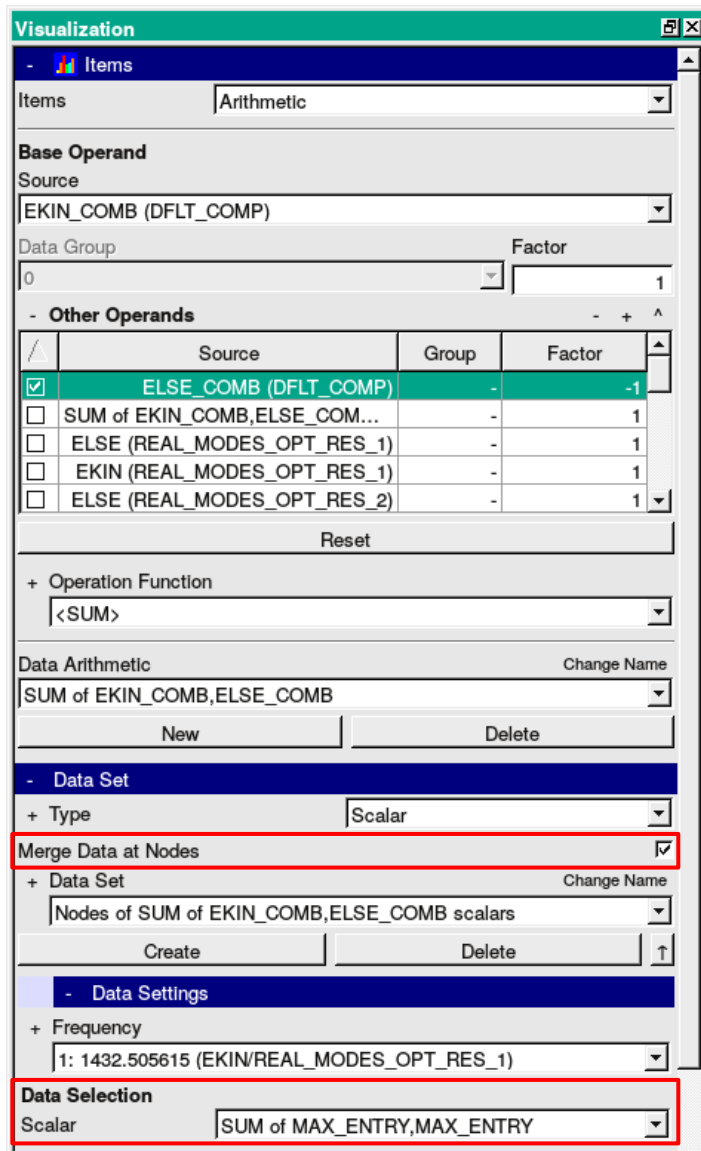

- **Merge data at Nodes** provides smoother data visualization

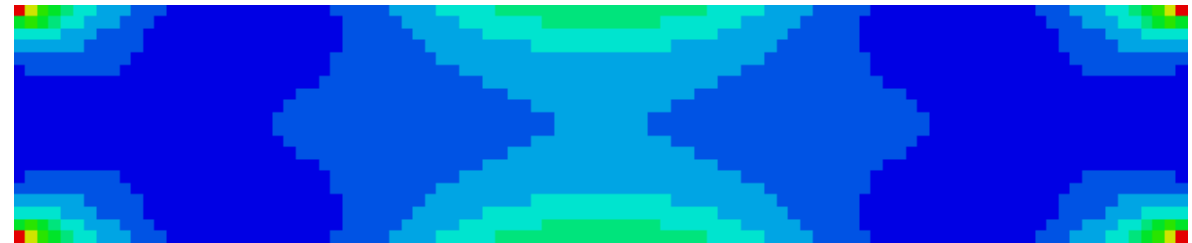

Data is visualized for each element node

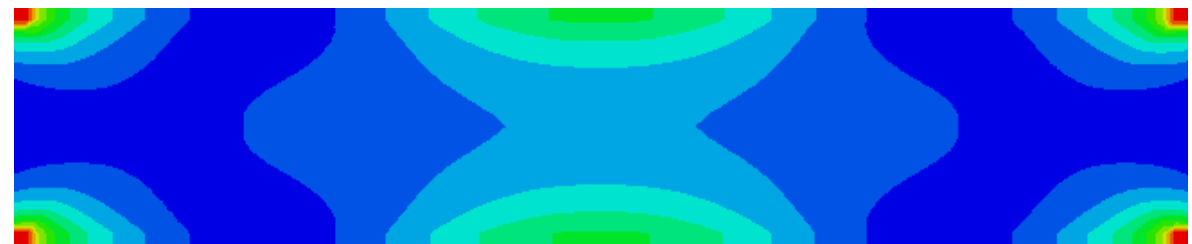

Data at node is merged for each element of that node

- Several data selection modes available

Extended postprocessing capabilities



VisPER 6 – New Postproc. Capabilities (3)

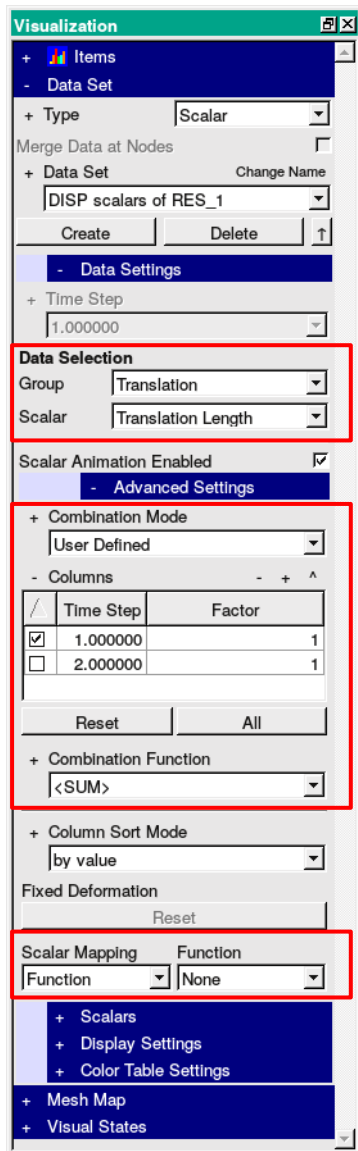

- **Data Group Selection** can be used to switch between Rotational and Translation part
- **Combination Mode = User Defined** allows to select and combine the columns of scalar results very flexibly
- **Scalar Mapping** mode switch
 - **Function** is used to transform the values by any defined PERMAS function
 - **Log10** allows to apply a logarithmic function (e.g. to post-process acoustic levels [dB])

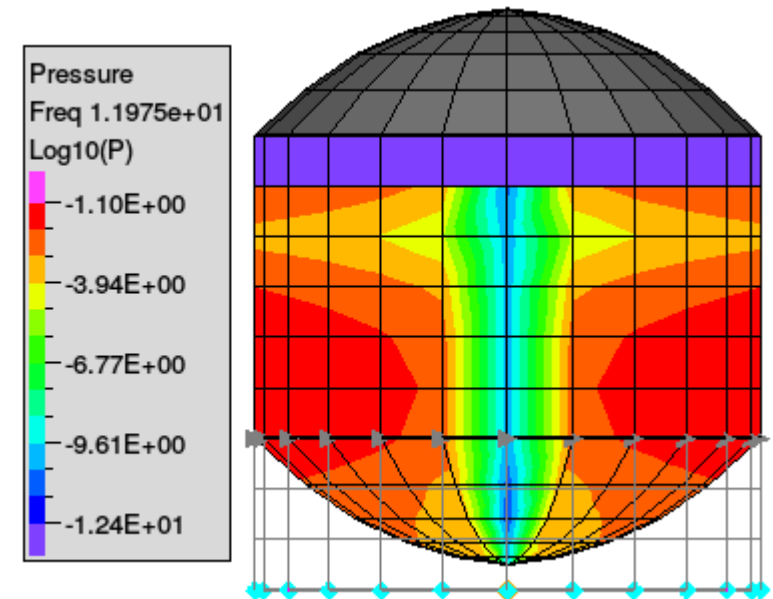

Extended postprocessing capabilities

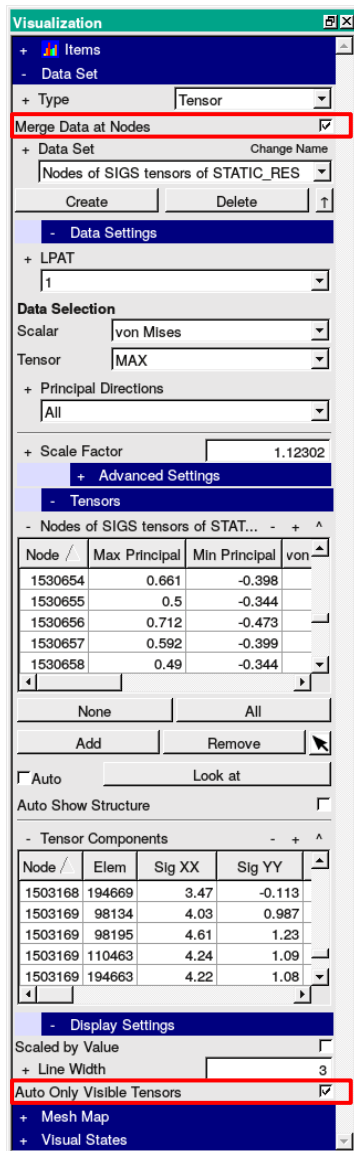

Tensor visualization added

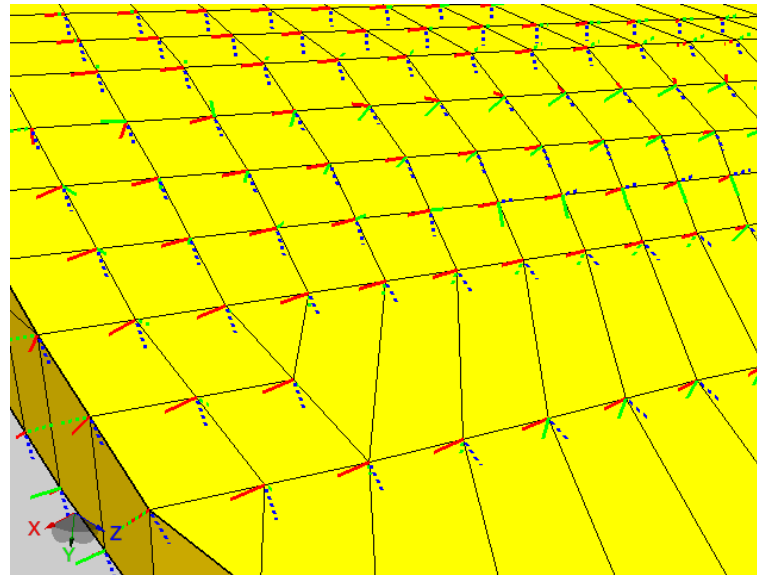

Avoid to clutter up visualization with too many tensor lines by

- Merge Data at Nodes
- Filter principle directions
- Hide tensor visualization at occluded nodes
- Select just a subset of nodes where tensors should be visualized

Detailed tensor data listed in table

Table contents may be exported as .csv

-  **VisPER** interaction can be recorded as Python script (Use `--logScript` to record **VisPER** session from startup)
- The Python scripting interface allows to replay such scripts and control the executed actions
- Several examples for application scenarios
 - Automated PERMAS-based element quality check (incl. ElementSet generation for further pre-processing)
 - Standardized post-processing (incl. image and video generation)
 - Automated report generation (e.g. as Word, Excel, PowerPoint)

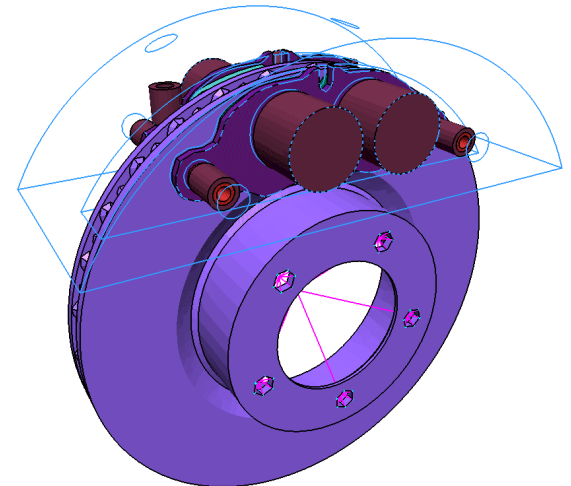



VisPER 6 – Enhanced visualization



- Some **Application Defaults** changed:

ContourMode = 'Full'

Contour line width = 2.0

(FeatureLine computation is done in background)

- **Arrow visualization**

- Tip angle configurable

- Type LineArrow modified

- **Midnodes** considered for visualization of geometry and results (Setting in CustomizeDlg)

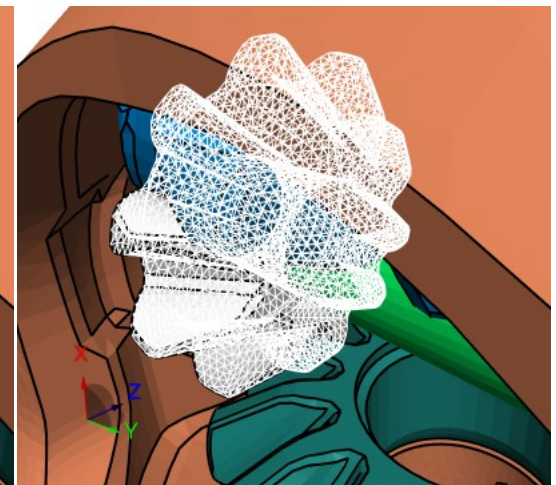
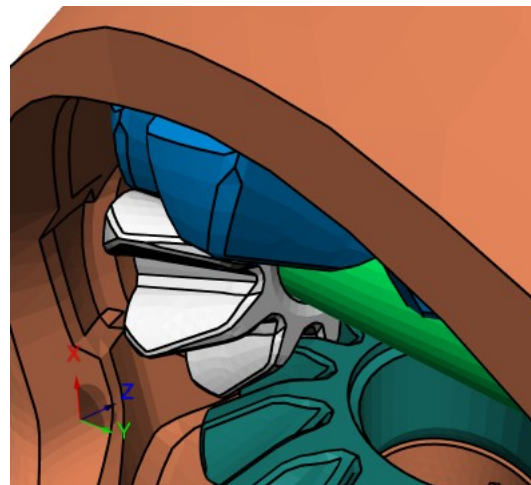
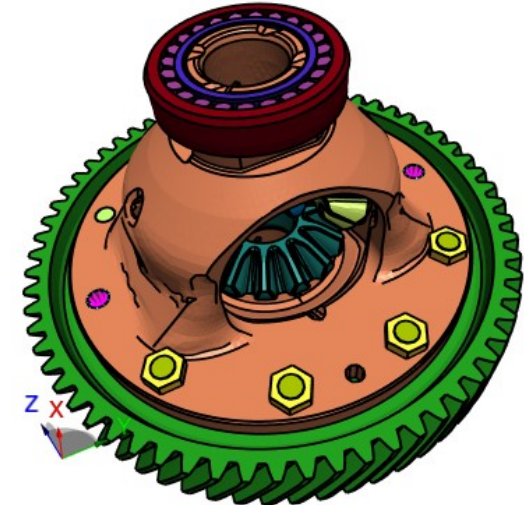
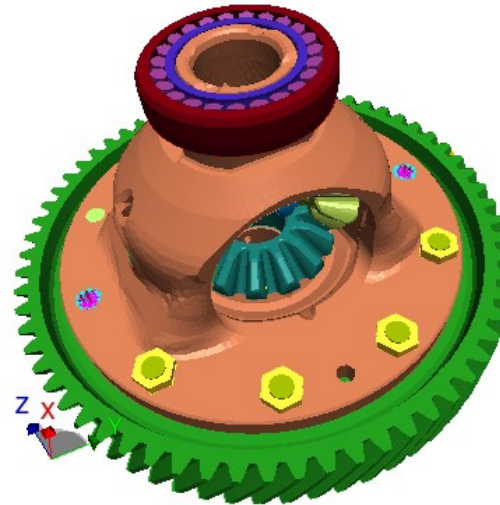

- **Selected entities** can be rendered translucent



Enhanced visualization

- **One-click-exit** if data has not been changed
- **Parallelization** of some initial computations accelerates startup and eliminates some first-use wait-times
(To suppress concurrent execution use `--single`)
-  **VisPER 6** uses new **3rd-party libraries**
(e.g. Qt 4.6.3 → 5.9.4 / Python 2.7.2 → 2.7.14 /
Mesa 7.11 → 11.2.2 / Boost 1.33 → 1.66 / ...)

These changes already fasten GUI interaction and allows access to new functionality in the next development version.

-  **VisPER** more and more catches up to PERMAS
No other pre-processor maps PERMAS better than **VisPER**
- Complex workflow scenarios are supported by several wizards
- Validation & verification become increasingly important due to the high level of detail of current FE models
Extended user access to data connections via context functionality ensures faster practice & allows quick validation of 3rd-party models
- Enhanced visualization capabilities provide better insight in model data
-  **VisPER** accelerated by use of modern software libraries and parallelization of initial compute tasks

Thanks to all colleagues who contributed to the current state of  **VisPER** especially to

R. Ernst, H. Kirchmeier, K. Makes (PERMAS development)

D. Trstenjak, T. Wang (**VisPER** development)

Thank you for your attention.

**Come, watch our demos and
talk with us about the challenges
of your daily work!**

Ove Sommer

INTES GmbH

Phone +49 (0)711 78499-0

www.intes.de